

mamava Preparing for Self Installation

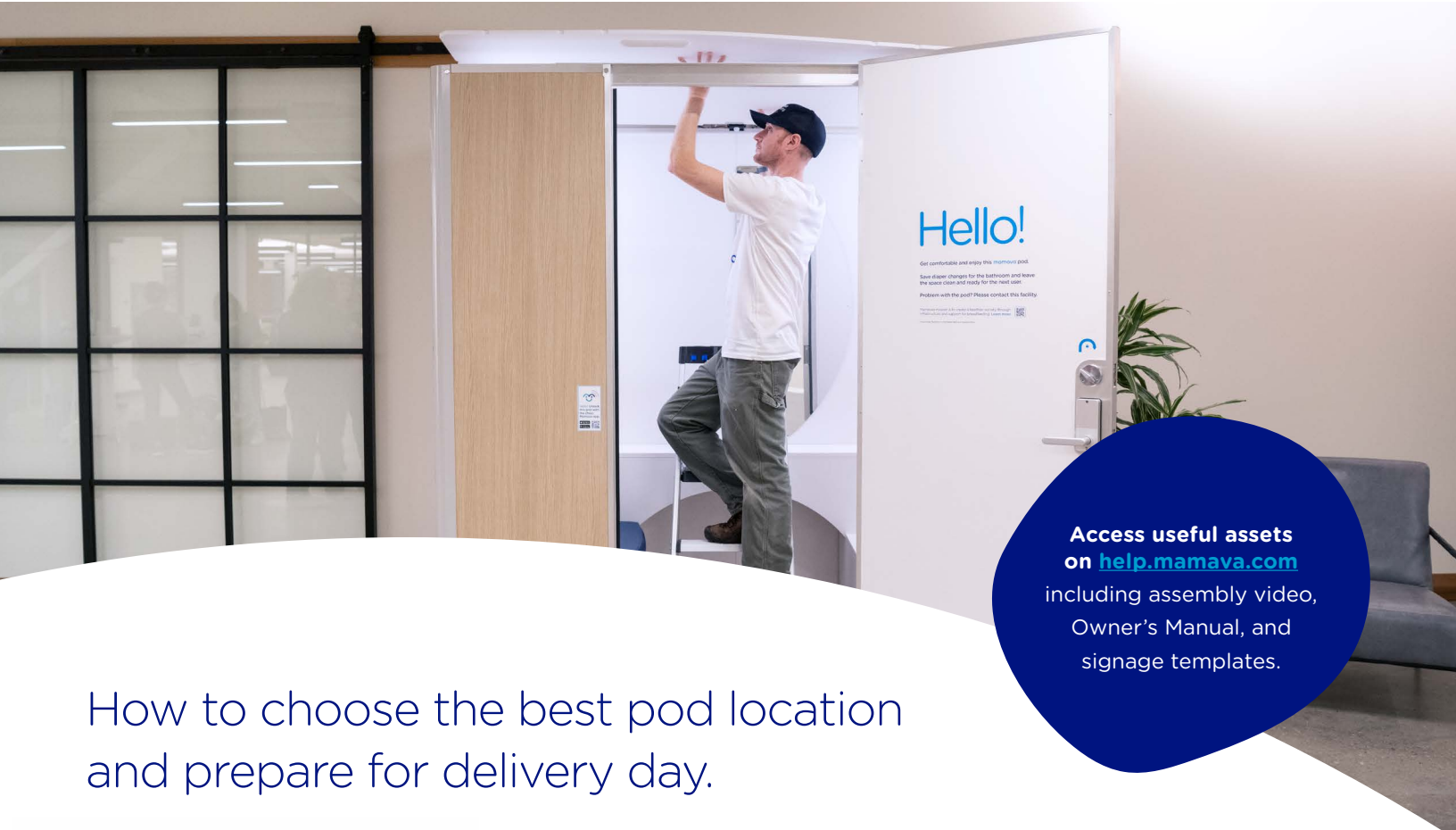

Access useful assets on help.mamava.com including assembly video, Owner's Manual, and signage templates.

How to choose the best pod location and prepare for delivery day.



Mamava XL

9'5"W x 5'4"D x 7'9"H*
Weight: 900 lb

Shipping pallet

4'5"W x 8'D x 6'H**
Total weight: 1,085 lb



Mamava Flex

6'7" W x 3'8" D x 7'9" H*
Weight: 465 lb

Shipping pallet

4'7" W x 7'10" D x 3'10" H**
Total weight: 755 lb



Mamava Solo

4'W x 4'D x 7'9"H*
Weight: 300 lb

Shipping pallet

7'10" W x 4'7" D x 2'7" H**
Total weight: 550 lb

*Includes pod and antenna height.

**Dimensions include the cribbing on the bottom of the pallet for jack/forklift access.

Placement Info for Facilities

1 Make accessibility, safety, and convenience top priority

Pods are only as accessible as the space they're placed in. Ensure placement doesn't degrade or impede audible or visible alarms. We also recommend placing your pod near a bathroom to provide easy access to a sink and changing table.

2 Be sure it fits the space

Mamava XL

9'5"W x 5'4"D x 7'9"H*
Door swing: 36"
Cord: 6'7" from the back center of the pod

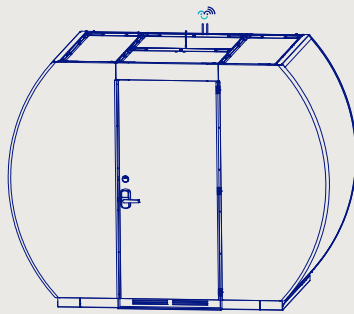

Mamava Flex

6'7"W x 3'8"D x 7'9"H*
Door swing: 32"
Cord: 4' from the back left corner of the pod

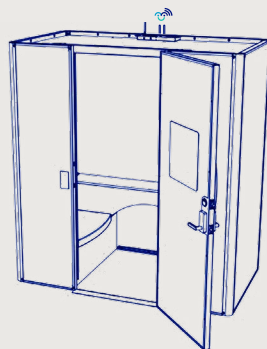

Mamava Solo

4'W x 4'D x 7'9"H*
Door swing: 32"
Cord: 4' from the back left corner of the pod

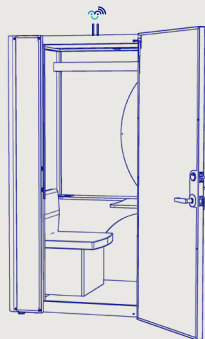

3 Ensure privacy

If you have an XL pod (with a perforated ceiling), avoid placing it in a stairwell, directly underneath security cameras, or anywhere that provides an overhead view.

4 Place within 2' of a standard outlet

Mamava pods come with a GFCI-protected electrical cord that plugs into a dedicated standard 15A or 20A 120V receptacle (Solo/Flex) or a 20A 120V receptacle (XL). **Be sure the cord does not span any walkways.**

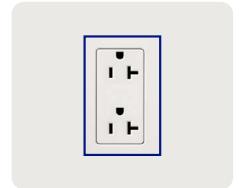

5 Consider temperature

Vent fans help move air, but do not heat or cool the pod. Place pod in an area serviced by your HVAC system.

6 Ensure cellular service or Wi-Fi

Breastfeeding parents need cell service or Wi-Fi to open pods with the Mamava app. **Does not apply to pods without Smart Access.**

7 Find a flat surface

Place your pod on a flat, consistent surface. Avoid grouted tiles, brick, or sloped floors. Low-pile carpet is fine.

Important: Mamava pods are intended for indoor use only. The unit should **not** be stored or installed in any area where it will be exposed to moisture, excessive humidity, wind or other outdoor elements, including extreme temperatures (below 40°F (4°C) or greater than 90°F (32°C)).

*Includes pod and antenna height.

Receiving Your Mamava Pod

Planning to self-install your new Mamava? Here's a list of everything you need to know to prepare for delivery day and get ready for the assembly process.

Be prepared to receive a large pallet

For Mamava's standard shipping and delivery, pods arrive unassembled in a stack of cardboard boxes on a large wooden pallet. Once offloaded, the pallet must be stored indoors. If you have multiple pods, the pallets cannot be stacked on top of one another. We recommend using a forklift or pallet jack to move your pallet from the truck. (Unless you have long forks, lift the pallet from the long side, not the narrow end.)

- For facilities **with a pallet jack, but not a forklift**, we can provide a liftgate truck to bring the pod from the truck down to the ground. Then use your pallet jack to bring it to your storage area, assembly space, or final installation spot.
- For facilities **without a pallet jack or a forklift**, we can provide a liftgate truck and pallet jack. The driver will bring the pallet inside the first threshold of the building (which will be the receiving area).

Plan your final pod location and walk the route

Walk the path you'll take from receiving your pallet to installing the pod and make sure the pallet will fit—factor in any stairs, width of hallways, etc.—and that you can move it. If you're concerned that it won't fit, Mamava can deliver the pod directly to the installation location for an additional fee. Contact customersuccess@mamava.com for information.

Assess pallet(s) for shipping damage

On delivery day, review the pallet(s) and packaging to ensure there hasn't been any damage in the shipping process. If the pallet(s) and/or boxes appear damaged, please tell the carrier to make appropriate notations in the BOL/POD, take photos, and contact customersuccess@mamava.com to let us know. If you receive the pallet and find damage to the boxes later, you will only have 10 days to submit the [damage claim form](#) to be eligible for repair and replacement.

Know where you will assemble the pod

For pod assembly, you'll need a ceiling clearance of at least 8'6" for XL pods to allow room for the side panels to slide in from above. Flex and Solo pods require a ceiling clearance of at least 7'9". Assemble the pod as close as possible to the final placement. Once assembled, Mamava pods can move short distances when the casters are engaged. (Read [here](#) about how to move a pod.)

Recruit your team

Mamava pods are easy to assemble, especially when you're prepared. It's helpful to recruit two people comfortable assembling kit-type furniture ahead of time. It takes two people about four hours to assemble an XL pod, (a third person can be helpful) and about two hours to assemble a Flex or a Solo.

Confirm assembly and send us a photo

Once you've assembled your pod and it's ready for parents, take a few horizontal photos of your pod head-on, as well as in its surroundings, to help parents recognize it on the app. Send pics to customersuccess@mamava.com so we can add these to our app.

Watch the
assembly video

Visit help.mamava.com to find helpful assembly resources.

Best Practices for Your New Mamava Pod

Your new Mamava pod will give breastfeeding parents a private space to pump or nurse. To help ensure your pod is the clean, serene oasis it's designed to be, here are some helpful tips on how to care for your new addition.

Care + cleaning

Parents will love your pod, especially if it's kept clean and sanitary. Be sure to put your pod on the same cleaning schedule as bathrooms at your facility.

Contact information

Use Mamava's [interior maintenance decal](#) to give parents up-to-date contact information at your facility should they need assistance or have any issues.

Celebrate + promote your pod

Our [handy guide has the tips and templates](#) you need to share news about your pod in internal communications, newsletters, social media, and more!

Additional resources

Visit Mamava's [Help Center](#) for information on how to help parents find your pod, best practices for care and cleaning recommendations, and more! To help educate your organization on lactation accommodations and supporting breastfeeding parents, please visit [Mamava's Resource library](#).

