

mamava Preparing for Professional Installation



Access useful assets on help.mamava.com including assembly video, Owner's Manual, and signage templates.

How to choose the best pod location and prepare for delivery day.



Mamava XL

9'3" W x 5'6" D x 7'7" H*
Weight: 700 lb

Shipping pallet

7'10" W x 4'7" D x 5'11" H**
Total weight: 1,050 lb



Mamava Flex

6'7" W x 3'8" D x 7'9" H*
Weight: 415 lb

Shipping pallet

4'7" W x 7'10" D x 3'10" H**
Total weight: 755 lb



Mamava Solo

4'W x 4'D x 7'9"H*
Weight: 300 lb

Shipping pallet

7'10" W x 4'7" D x 2'7" H**
Total weight: 550 lb

*Includes pod and antenna height.

**Dimensions include the cribbing on the bottom of the pallet for jack/forklift access.

Placement Info for Facilities

1 Make accessibility, safety, and convenience top priority

Pods are only as accessible as the space they're placed in. Ensure placement doesn't degrade or impede audible or visible alarms. We also recommend placing your pod near a bathroom to provide easy access to a sink and changing table.

2 Be sure it fits the space

Mamava XL

9'3"W x 5'6"D x 7'7"H*
Door swing: 35"
Cord: 10' from the bottom of the back right wall panel

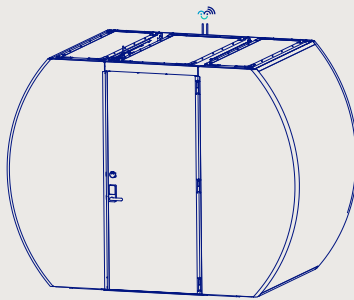

Mamava Flex

6'7"W x 3'8"D x 7'9"H*
Door swing: 32"
Cord: 4' from the back left corner of the pod

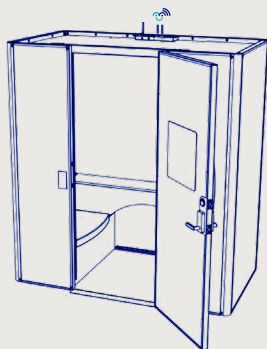

Mamava Solo

4'W x 4'D x 7'9"H*
Door swing: 32"
Cord: 4' from the back left corner of the pod

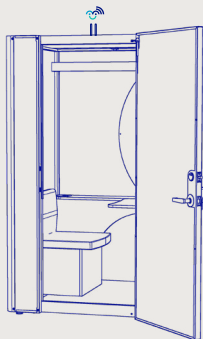

3 Ensure privacy

If you have an XL pod (with a perforated ceiling), avoid placing it in a stairwell, directly underneath security cameras, or anywhere that provides an overhead view.

4 Place within 2' of a standard outlet

Mamava pods come with a GFCI-protected electrical cord that plugs into a dedicated standard 15A or 20A 120V receptacle (Solo/Flex) or a 20A 120V receptacle (XL). **Be sure the cord does not span any walkways.**

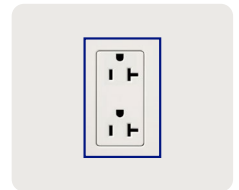

5 Consider temperature

Vent fans help move air, but do not heat or cool the pod. Place pod in an area serviced by your HVAC system.

6 Ensure cellular service or Wi-Fi

Breastfeeding parents need cell service or Wi-Fi to open pods with the Mamava app. **Does not apply to pods without Smart Access.**

7 Find a flat surface

Place your pod on a flat, consistent surface. Avoid grouted tiles, brick, or sloped floors. Low-pile carpet is fine.

Important: Mamava pods are intended for indoor use only. The unit should **not** be stored or installed in any area where it will be exposed to moisture, excessive humidity, wind or other outdoor elements, including extreme temperatures (below 40°F (4°C) or greater than 90°F (32°C)).

*Includes pod and antenna height.

Onsite Requirements

Communicate site-specific security or building access requirements

If your facility has any security or access protocols, please include these in your installation and delivery questionnaire, and share with your dedicated Customer Success Manager.

Ensure necessary ceiling clearance for assembly

You'll need a ceiling clearance of at least 8'4" for XL pods to allow room for the side panels to slide in from above. Flex and Solo pods require a ceiling clearance of at least 7'9".

Ensure an obstacle-free install space

Be sure to clear away any furniture or debris that could hinder the install team in the pod assembly location.

Confirm the future pod location has a standard 15A or 20A 120V (Solo/Flex) or a 20A 120V (XL) electrical outlet

Mamava pods have a GFCI plug and, once plugged in, are ready to go. Make sure your installation location has the correct outlet within 2' of where you plan to place the pod.

Ensure your point of contact knows their installation day responsibilities

Have someone onsite who will meet the Mamava assembly crew, guide them to the pod location, and be available to answer any questions during the installation.

Authorize the installation and sign off

Once the crew has assembled the Mamava pod, use the [post-installation checklist](#) to check all pod functionality and make sure you're satisfied with the installation service and final product. Please note that this will be the time to note anything unsatisfactory. Your completed, signed checklist is your acceptance of services rendered.

Seismic Bracketing Kit

If you ordered Mamava's Seismic Bracketing Kit (available for XL pods) to meet safety and/or building codes, it will ship separately in advance of your pod and requires site preparation by your team. Please note that you're responsible for drilling the anchor holes in the concrete floor where the pod will be placed, installing anchors, and fastening the strut channels to the floor. Pod assembly—even with Mamava's professional installation services—cannot occur until this step is complete. (You'll find detailed instructions in the [assembly guide](#) that comes with the kit.)

Best Practices for Your New Mamava Pod

Your new Mamava pod will give breastfeeding parents a private space to pump or nurse. To help ensure your pod is the clean, serene oasis it's designed to be, here are some helpful tips on how to care for your new addition.

Care + cleaning

Parents will love your pod, especially if it's kept clean and sanitary. Be sure to put your pod on the same cleaning schedule as bathrooms at your facility.

Contact information

Use Mamava's [interior maintenance decal](#) to give parents up-to-date contact information at your facility should they need assistance or have any issues.

Celebrate + promote your pod

Our [handy guide has the tips and templates](#) you need to share news about your pod in internal communications, newsletters, social media, and more!

Additional resources

Visit Mamava's [Help Center](#) for information on how to help parents find your pod, best practices for care and cleaning recommendations, and more! To help educate folks at your organization on lactation accommodations and supporting breastfeeding parents, please visit [Mamava's Resource library](#).

